

TGD 45 / 1 100 - 360

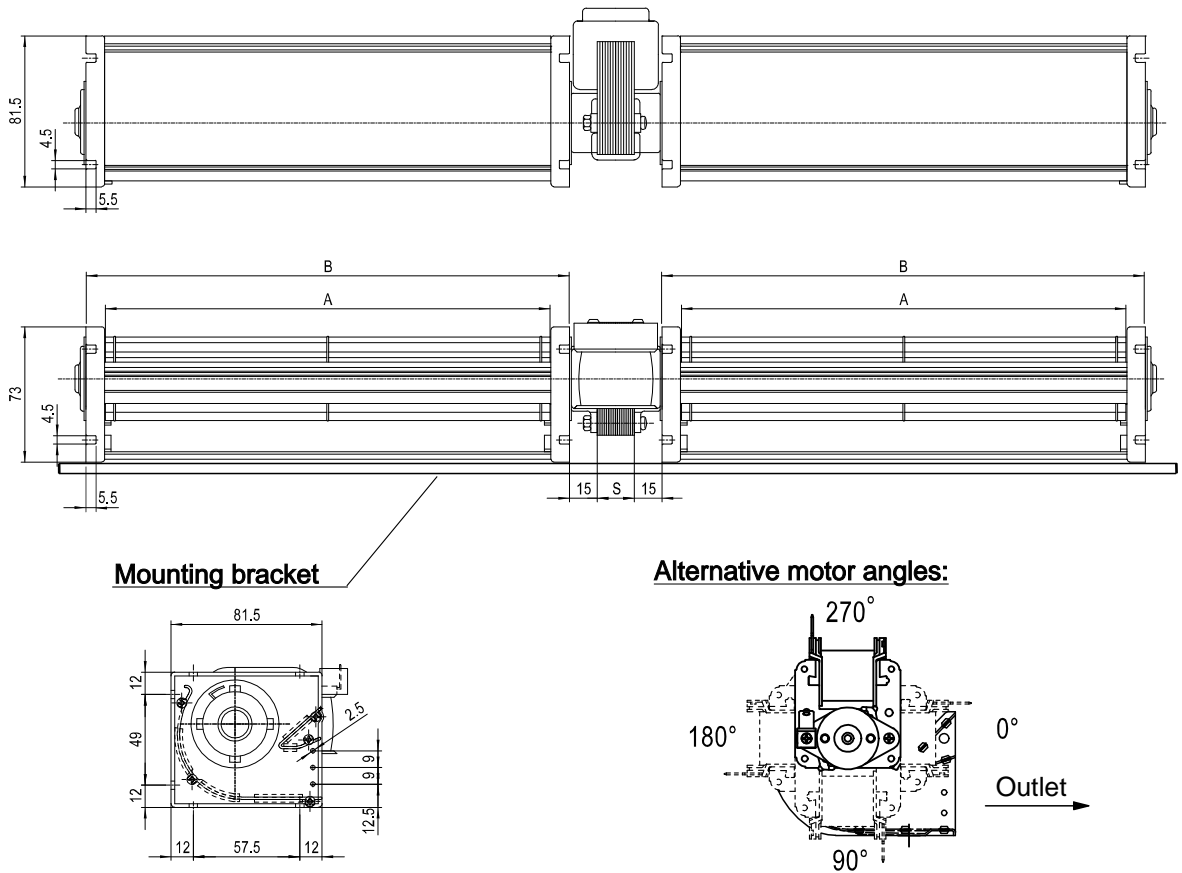

A mid range option that is in regular use in electric fires, microwave ovens and refrigerators. Standard for all motor types: insulation class F or H; motor available encapsulated bobbin, 230V/50Hz alt. 120V/60Hz alt. 24V AC
 Special low profile through-flow version also available (see specific datasheet for TGD 45/2)

Stack size (S) : 15/20/30

Blower	A	B
TGD 45/1-100	100	121
TGD 45/1-120	120	141
TGD 45/1-150	150	171
TGD 45/1-180	180	201
TGD 45/1-200	200	221
TGD 45/1-240	240	261
TGD 45/1-250	250	271
TGD 45/1-300	300	321
TGD 45/1-360	360	381

Description	
Airflow	Up to 330 m ³ /h
Input Power	Up to 40 W
Pressure	Up to 40 Pa
Speed	Up to 2000 RPM

Crossflow blower description example:

TGD 45 / 1 - 180 / 30

Crossflow blower _____

Double _____

Wheel diameter _____

Housing's profile 1/2 _____

Length _____

Stack size _____